

## Adhesion Properties of Modified Bitumen

A. Grigorov, O. Mardupenko, I. Sinkevich, A. Tul'skaya\*

National Technical University "Kharkiv Polytechnic Institute", Kharkiv, Ukraine

Received February 5, 2020; Accepted April 29, 2020

---

### Abstract

The article presents the results of determining the adhesion properties of bitumen modified with polymeric additives based on polypropylene and polystyrene foam with graphite additives. It has been found that a sample with the addition of 3% (mass.) Polypropylene (peel strength of the plate 2.47 N/cm<sup>2</sup>; peel of the coating from the marble plate at a speed of 7000 rpm; shift of marble plates by 5000 rpm) has the best adhesive properties. And at a polymer concentration of 10% (mass.), The best properties are manifested in a sample containing polystyrene foam with graphite additives (plate tear-off force 3.15 N/cm<sup>2</sup>; tear-off occurs at a speed of 8000 rpm; marble plates shift by 8000 rpm ).

**Keywords:** Prospect; structure; reservoir quality; volumetric.

---

## 1. Introduction

Nowadays bitumen, that has been produced from the petroleum residue, is the most widespread construction materials which plays the role of a binder in various compositions. According to that, the main properties of bitumen, which determine its interaction with various mineral components (sand, marble, gravel) and which affect the reliability of the structures, are adhesive properties.

## 2. Aim and scope

The adhesive mechanism for bitumen and mineral component can be considered as inter-phase interaction between surfaces of different origin. Here, several independent stages can be distinguished. In the first step bitumen is transferred to a liquid state by heating, as a result of there is a close contact between the molecules of bitumen and the mineral component. In the next step this contact develops into intermolecular interaction, which is carried out through physical and chemical forces. This interaction ends at the next step, when the temperature of bitumen-mineral composition goes down [1].

The reliability of bitumen-mineral structures decreases mainly due to insufficient adhesion and weak intermolecular interaction between bitumen and the mineral component. From then on, development of new composition and improvement of the technology for producing a high-adhesive bitumen binder is a very relevant task.

More than 90% of bitumen produced in Ukraine has been obtained by oxidation of oil residue (fuel oil or tar) by atmospheric oxygen. A significant drawback of this process is high energy consumption and using of raw materials, which are widely used in other technological processes. We should also consider the fact that the obtained oxidized bitumen does not have very high operational properties, as evidenced by numerous research devoted to improving of bitumen quality [2-4].

Among the promising areas for improving the quality of bitumen there should be mentioned the process of polymer modification of bitumen that implies changing of its physicochemical structure and rheology, improving of adhesion, viscosity, extensibility, and resistance to high and low temperatures. So, there are plenty of research [5-7] devoted to bitumen additives such as a copolymer of butadiene and styrene SBS (styrene - butadiene - styrene). Addition

of 3% SBS-type polymer to the bitumen has made it possible to increase the lifespan of asphalt concrete and stability of asphalt concrete in water, sulfuric acid and diesel fuel. Bitumen has become more elastic. Rubber thermoplastic elastomers RTEP has been added as the dark colored granules of butadiene (divinyl) rubber filled with calcium carbonate (6-10%) and sulfur (3-6%). This type of additive increases the heat resistance of bitumen without changing the temperature of cracking at low temperatures [8]. In [9] the positive effect of synthetic rubbers (isoprene SKI, divinyl SKD, divinyl-styrene SKS, divinyl-methyl SKMS, ethylene propylene SKEPT copolymers) of general purpose on the properties of bitumen has been studied. Addition of rubber into bitumen increases the plasticity rate from 320–340K to 355–370K.

Having analyzed the sources, it should be mentioned that modification of bitumen with polymer additives is reasonable exclusively to commodity product obtained by oxidation or concentration of oil residue. Accordingly, the aim of current research is to study the basic properties, as exemplified by adhesion, of bitumen obtained by direct modification of the base hydrocarbon fraction by polymers.

Considering the current global trends in the production of marketable petroleum products, aimed at expanding the raw material base, for a set of involvement of secondary raw materials in the technological process, we propose to obtain bitumen by compounding raw materials consisting of industrial and household waste. A hydrocarbon fraction with a boiling point above 350°C obtained from oil sludge was selected as the base for the production of bitumen [10]. To transfer the base fraction to the properties of commercial bitumen, it was modified with wastes shredded to a size of 1 × 1 mm, polypropylene (PP) and polystyrene foam with graphite additives (PPSG), which were introduced into the base fraction with constant stirring.

### 3. Experimental research

In laboratory conditions, according to the described technology, the following samples of modified bitumen were obtained:

- sample No. 1 (fraction + 3% (mass.) PP),
- sample No. 2 (fraction + 3% (mass.) PSG),
- sample No. 3 (fraction + 10% (mass.) PP),
- sample No. 4 (fraction + 10% (mass.) PSG).

Then we have analyzed adhesive properties of obtained samples.

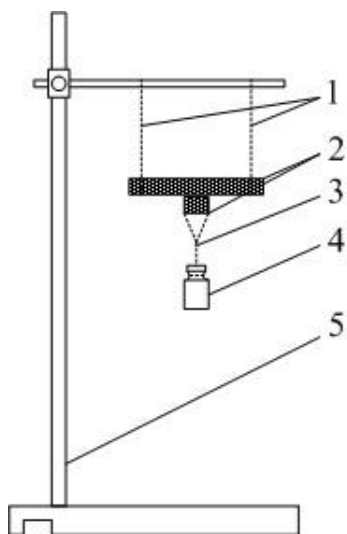

Fig. 1. Determination of adhesive properties by the value of gravity force: 1 – plates mount; 2 – marble plates; 3 – load mount; 4 – load; 5 – tripod

The first method considered studying of adhesion properties of a bitumen based on gravity forces (Fig. 1). A tested bitumen sample has been heated up to a 430 K and spread on the marble plate with dimensions of 50 × 10 × 5 mm, so that the interaction area was 1 cm<sup>2</sup>. Then, the same marble plate was attached to the first one “cross to cross” and then pressed with 500 g load. After exposure for 5 minutes this design has been hung on a tripod by the upper plate, and a load of a certain mass was suspended from the bottom. The tests were carried out after the separation of marble plates from each other. The results of laboratory tests are given in table 1.

Table 1. Research of adhesion properties using the gravity force

Nº	Name of indicator	Sample			
		sample Nº 1	sample Nº 2	sample Nº 3	sample Nº 4
1.	Mass of plate+mass of load, g	11.5+240	11.5+260	11.5+150	11.5+310
2.	Tearing force, N/cm <sup>2</sup>	2.47	2.66	1.58	3.15

Analyzing the obtained results, it has been noted that in low concentration area (about 3% (mass.)) a sample containing PP additive has a higher adhesive properties and plate tearing force of 2.47 N/cm<sup>2</sup>. And in the area of higher concentrations at the level of 10% (mass.) the best adhesive properties have been performed by samples with a tearing force of 3.15 N/cm<sup>2</sup> with a PPSG content.

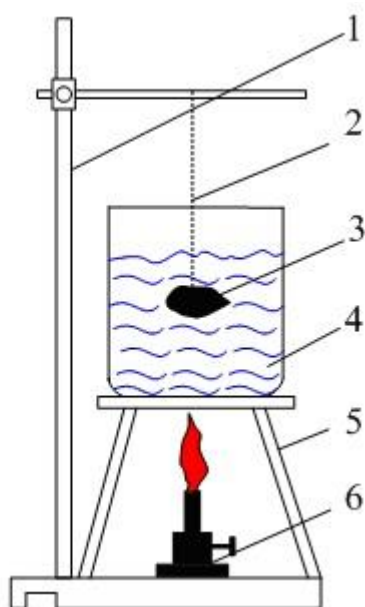

Fig. 2. Visual determination of adhesive properties: 1 - tripod; 2 - mount; 3 - granite stone coated by bitumen; 4 - a glass of water; 5 - stand; 6 - gas burner

The adhesive properties of the samples under have been also determined by the visual method (Fig. 2) which has been performed by heating of samples up to 430K, followed by dipping of pyramidal granite stones into them and cooling of the samples. After that samples were placed in a glass of boiling water for 30 minutes. After boiling, the samples have been taken out of the water, cooled and compared to a standard sample.

Studies have shown that all examined bitumen compositions have high adhesive properties, since during the test the samples completely retained their coating.

The next step in the study of the adhesive properties of the obtained bitumen samples was the effect of centrifugal force. The method included dipping into prepared bitumen prepared marble plates with dimensions of 50 × 10 × 5 mm heated up to 430K.

Further, the obtained samples have been cooled and placed in a laboratory centrifuge with subsequent determination of the rotation speed at which damage to the integrity of the coating of the sample has been observed. The results of laboratory studies are presented in Fig. 3-4.

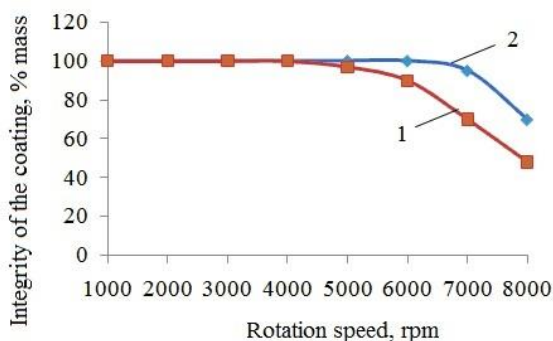

Fig. 3. Tests of compositions with 3% polymer spread on a marble plate in a centrifuge: 1 - PPSG; 2 - PP

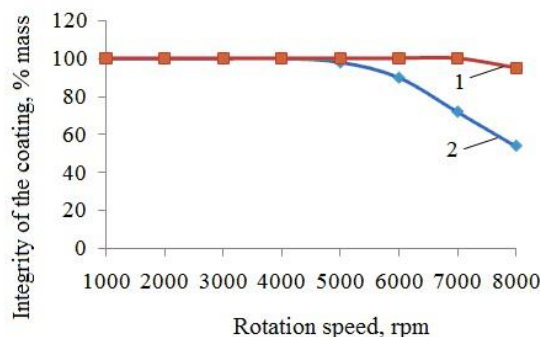

Fig. 4. Tests of compositions with 10% polymer spread on a marble plate in a centrifuge: 1 - PPSG; 2 - PP

At the polymer concentration is about 3% (mass.) (Fig. 3), sample with the addition of PP has shown the best adhesive properties, since peeling of the coating from the marble plate is observed only at a rotation speed of 7000 rpm. At a concentration of 10% (mass.), the best adhesive properties are observed in the sample with the addition of PSPG. Detachment of the coating occurs at a speed of 8000 rpm (Fig. 4).

It is also very interesting to determine the adhesion properties of bitumen spread between two marble plates in the centrifugal forces field of centrifugal forces (Fig. 5-6).

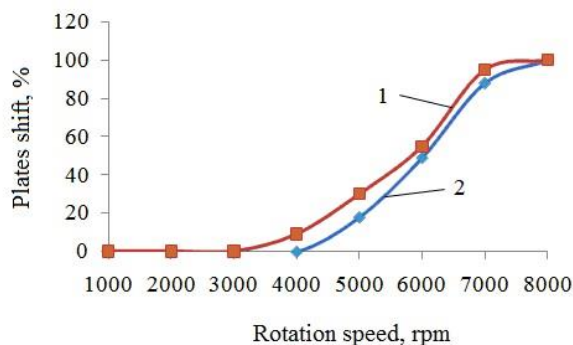

Fig. 5. Tests of compositions with 3% polymer spread between the marble plates in a centrifuge: 1 – PSPG; 2 – PP

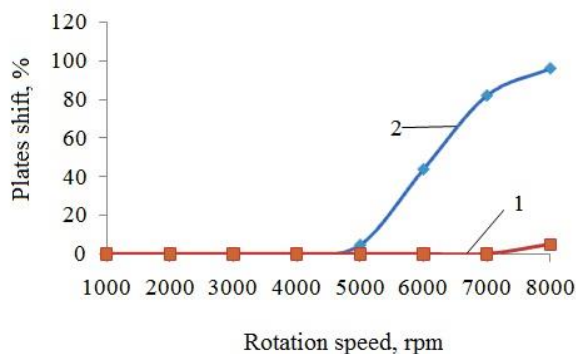

Fig. 6. Tests of compositions with 10% polymer spread between the marble plates in a centrifuge: 1 – PSPG; 2 – PP

The method of spreading the bitumen between the plates was performed similarly to the method of determining adhesive properties under the action of gravitational forces. The only difference was that the plates were not placed "cross to cross", but pressed against each other. The tests were carried out in a centrifuge until the moment when one plate is shifted relative to another, while the centrifuge rotational speed and shear distance were fixed.

The results has also confirmed previous studies of another methods for determining adhesive properties. The best adhesive properties at a concentration of 3% (mass.) has a sample with the addition of PP (plate shift by 5000 rpm), and at a concentration of 10% (mass.) - the sample with the addition of PSPG (plate shift by 8000 rpm).

#### 4. Conclusions

The reliability of bitumen-mineral compositions that contain bitumen as a binder, is largely determined by the adhesive properties of bitumen distributed among mineral materials. Among the additives that improve the adhesive properties, the polymers play the most important role. They improve also the softening temperature of bitumen, water resistance, and resistance to chemical reagents.

Existing technologies for producing bitumen with improved properties suggest the modification of commodity bitumen obtained by oxidation or concentration of oil residues. In contrast to this, we proposed a technology for producing bitumen, based on the modification of the fraction heated up to 430 K obtained from oil sludge with polymer waste from polypropylene and polystyrene foam with graphite additives.

Studies on the determination of the adhesion properties of modified bitumen by various methods have shown that, at a polymer concentration of 3% (mass.) sample containing polypropylene has the best adhesion properties (tearing force of the plate 2.47 N/sm<sup>2</sup>; peeling of the coating from the marble plate at speed 7000 rpm; shift of marble plates by 5000 rpm). At a polymer concentration of 10% (mass.) the best properties are noticed on a sample containing polystyrene foam with graphite additives (tearing force 3.15 N/sm<sup>2</sup>; marble plates shift by 8000 rpm).

Summarizing the results, we have noted that the modified bitumen considered has very high adhesive properties, which can be used in the development and practical application of building bitumen-mineral structures of various functional purposes.

## References

- [1] Abdulin AI. Cementitious materials from bitumen [Electronic source]: ucheb. posobie. Kazan. nats. issled. Tekhnol, KNITU: Kazan': 2012; 100 p.
- [2] Belyaev PS. Increase of quality of petroleum bitumen through modification by polymers obtained from processed tyres. Vestnik TGTU.2003; 9(1): 63-69.
- [3] Shukhov VI. Influence of different types of surfactants on quality of concrete. Vestnik Khar'kovskogo natsional'nogo avtomobil'nodorozhnogo universiteta. 2008; vol 40: 57-58.
- [4] Abdullin AI. The use of polysiloxane additives as adhesives for petroleum road bitumen. Vestnik Kazanskogo tekhnologicheskogo universiteta. 2010; 10: 634-635.
- [5] Zolotarev VA. The effect of the modification of bitumen of SBS-type polymers on the stability of asphalt-polymer concrete in liquid aggressive areas. Avtomobil'nye dorogi. 2014; 6 (242): 18-26.
- [6] Kiselev VP. The use of products of joint processing of stone and brown coal, oil residues and synthetic polymers to produce high-quality road binders. Izvestiya vysshikh uchebnykh zavedenii. Stroitel'stvo. 2008; 9: 17-22.
- [7] Balabanov VB. The use of organic-mineral mixtures based on cationic bitumen emulsions and emulsions based on modified bitumen. Vestnik Irkutskogo gosudarstvennogo tekhnicheskogo universiteta. 2011; 52(5): 78-83.
- [8] ODM 218.3.001-2006 Guidelines for the use of polymer-dispersed reinforcement of asphalt concrete using rubber thermoplastic (RTEP): Rosavtodor: Moscow, 2006; 30 p.
- [9] Mullakhmetov NR. Modification of road bitumen with rubber. Vestnik Kazanskogo tekhnologicheskogo universiteta. 2010; 7: 467-468.
- [10] Mardupenko A, Grigorov A, Sinkevich I, Tulskeya A. Oil sludge as source of a valuable carbon raw material. Petroleum & Coal, 2018; 60(3): 353-357.

---

*To whom correspondence should be addressed: Dr. Alena Tulskeya, National Technical University "Kharkiv Polytechnic Institute", Kharkiv, Ukraine, E-mail: [fuel.khpi@gmail.com](mailto:fuel.khpi@gmail.com)*